

PARTS INCLUDED IN YOUR KIT

- 1 Pair rails (L&R)
- Roll top assembly
- Bulkhead seals (1x 1/4" & 1x 3/4" thick) (1x 1/4" & 1x 1/4" thick)

1 HARDWARE BAG INCLUDING

- 6 x Clamps (8' ft trucks incl. 8)
- 2 x Strap assembly clamps
- 4 x D Shaped cab bumpers
- 4 x Mounting bolts
- 4 x Rubber washers
- 4 x Large flat washers
- 4 x Lock nuts

TOOLS RECOMMENDED

- 9/16 Wrench or socket
- 1/2 Wrench or socket

1 Install the bulkhead seal to the top of the bulkhead at the edge of the bed opening. If the truck **does NOT** have a drop-in bed liner, use the 3/4" seal. If the truck **does** have a drop-in bed liner, use the 1/4" seal.

2 Position the rail with the slotted bracket all of the way forward toward the cab of the vehicle. If the truck is equipped with a drop in bedliner remove the foam pad located on the slotted bracket as shown in Fig. 2a.

3 Position the clamp as close to the front end of the rail as possible, 12" or less from the end. Make sure the rail is clamped square and level.

NOTE: adjusting the cover placement in step 14 may bring the install back to rail placement.

NOTE: Some drop-in liners may require trimming in the corners to fit the rail into the opening.

4 Make sure the clamp is inserted all the way up into the rail and the clamp teeth engage the ribs along the inside of the rail squarely.

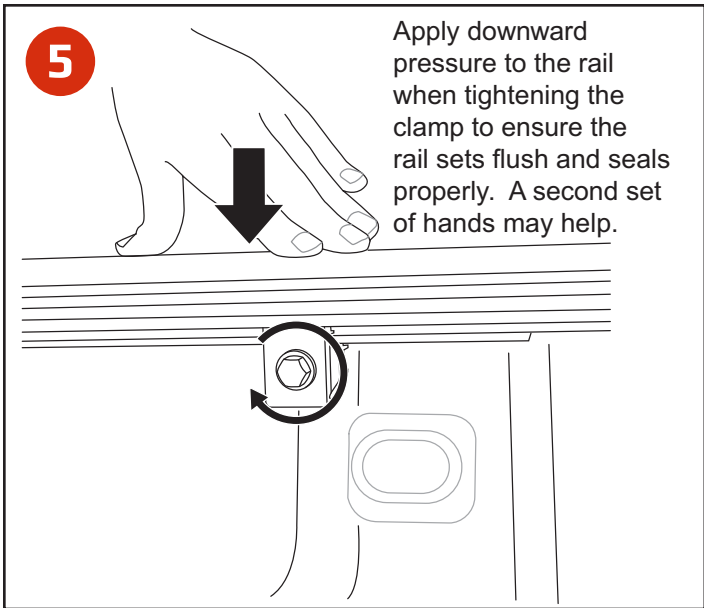

5 Apply downward pressure to the rail when tightening the clamp to ensure the rail sets flush and seals properly. A second set of hands may help.

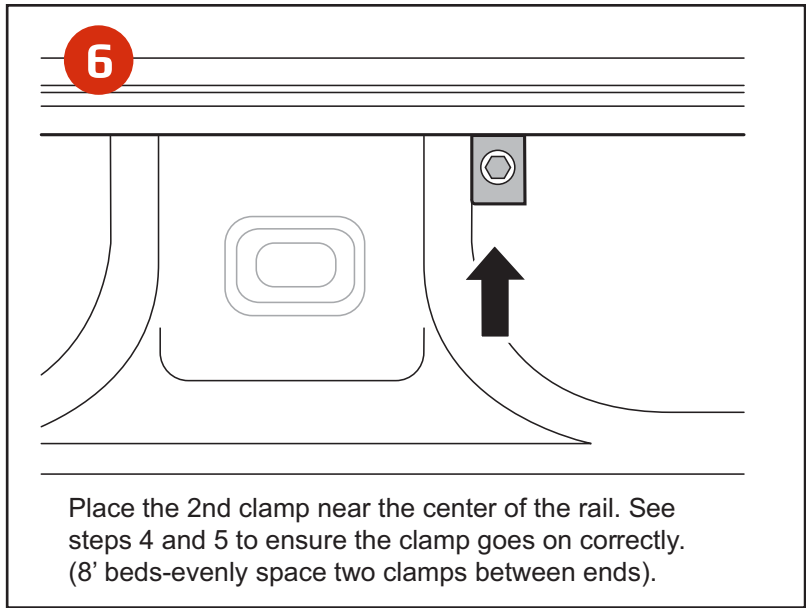

6 Place the 2nd clamp near the center of the rail. See steps 4 and 5 to ensure the clamp goes on correctly. (8' beds-evenly space two clamps between ends).

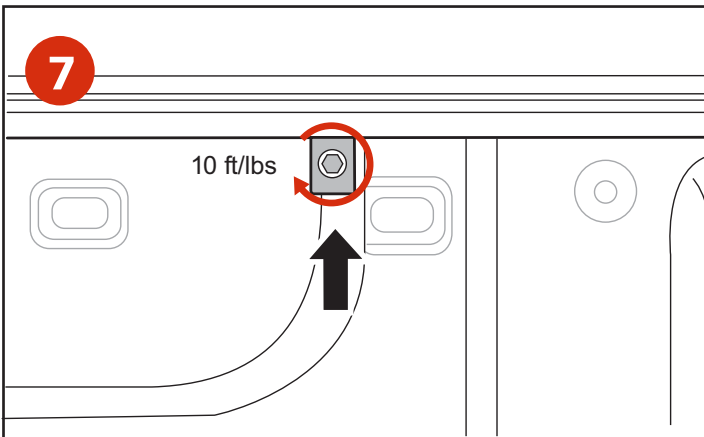

7 Place the rear clamp as close to the tailgate as possible, it should be less than 12". Check that all of the clamps are square and tight at 10 ft/lbs of torque.

CAUTION: over tightening the clamps could cause warping of the bed cap.

NOTE: adjusting the cover placement in step 14 may bring the install back to rail placement.

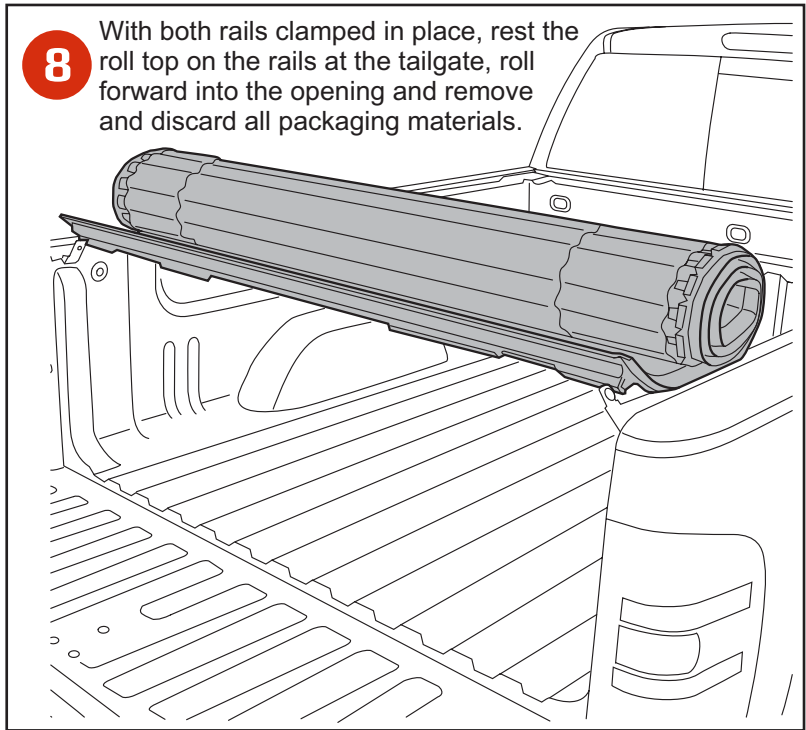

8 With both rails clamped in place, rest the roll top on the rails at the tailgate, roll forward into the opening and remove and discard all packaging materials.

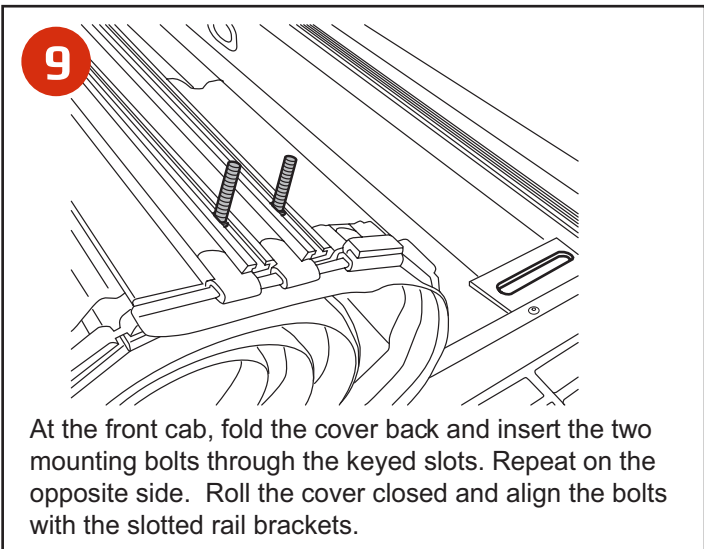

9 At the front cab, fold the cover back and insert the two mounting bolts through the keyed slots. Repeat on the opposite side. Roll the cover closed and align the bolts with the slotted rail brackets.

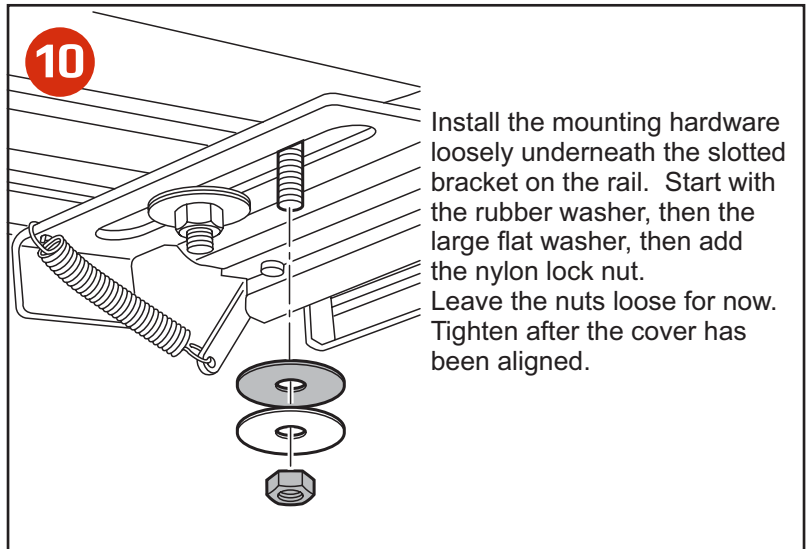

10 Install the mounting hardware loosely underneath the slotted bracket on the rail. Start with the rubber washer, then the large flat washer, then add the nylon lock nut. Leave the nuts loose for now. Tighten after the cover has been aligned.

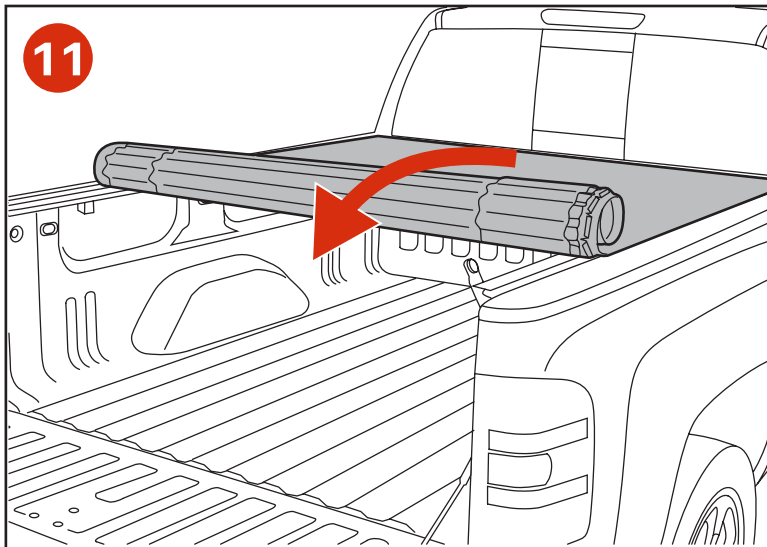

11

It is necessary to check that the roll top fits correctly between the rails. Roll the cover from front to back and back to front to verify it rolls freely on the rails.

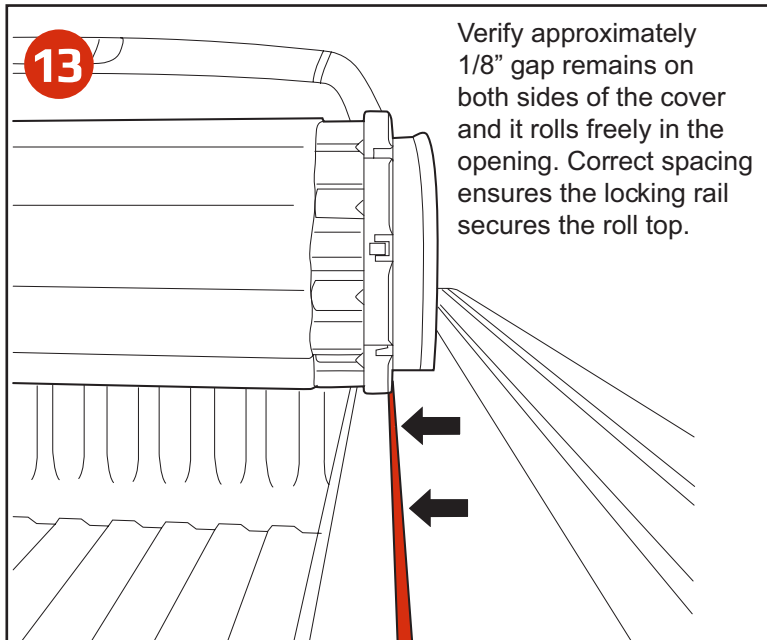

13

Verify approximately 1/8" gap remains on both sides of the cover and it rolls freely in the opening. Correct spacing ensures the locking rail secures the roll top.

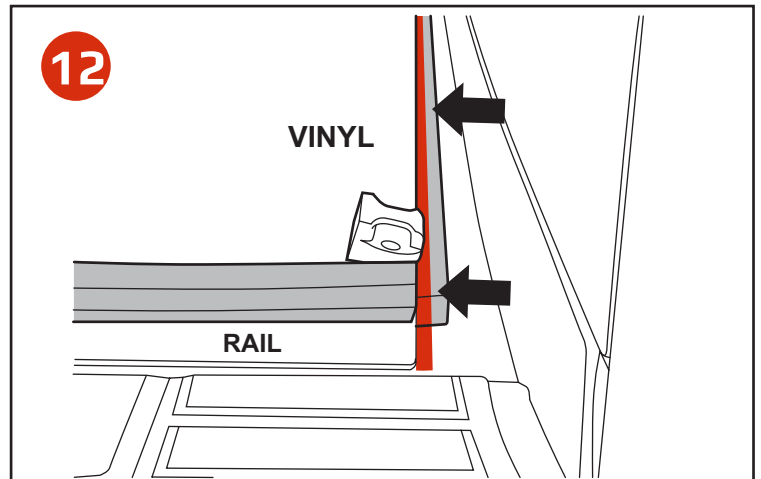

12

Align the front vinyl edge of the cover with the front edge of the rail (not the rubber seal).

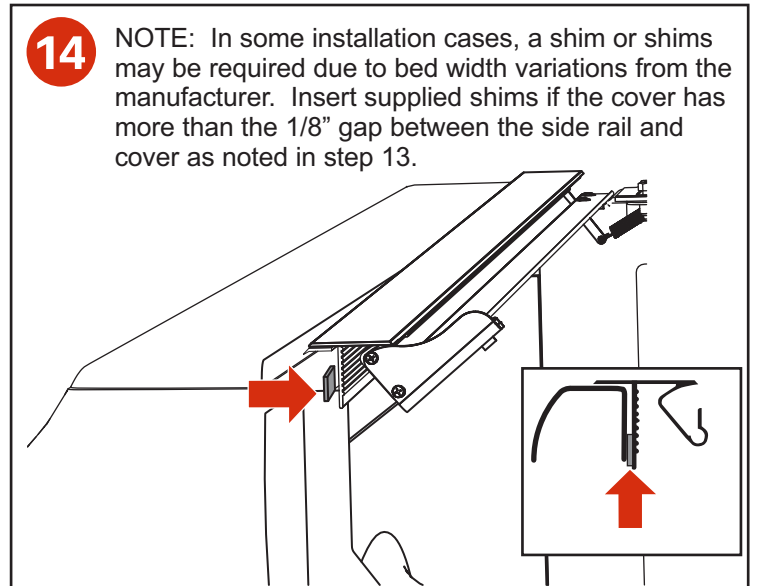

14

NOTE: In some installation cases, a shim or shims may be required due to bed width variations from the manufacturer. Insert supplied shims if the cover has more than the 1/8" gap between the side rail and cover as noted in step 13.

Remove the rail clamps and adhere the shim to the lower inside of the cover rail. Follow the instructions starting from step 3.

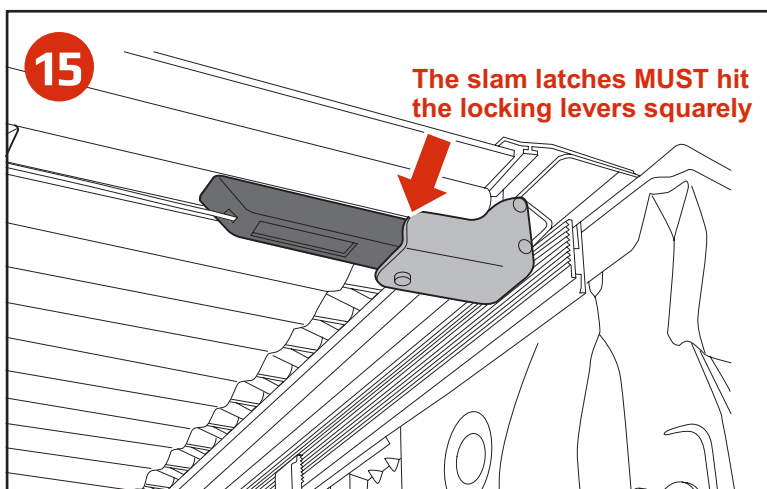

15

The slam latches **MUST** hit the locking levers squarely

When correctly installed, the vinyl edges of roll top align squarely with the rails in the 4 corners. The latch assembly will align with the silver locking levers at the tailgate on each side.

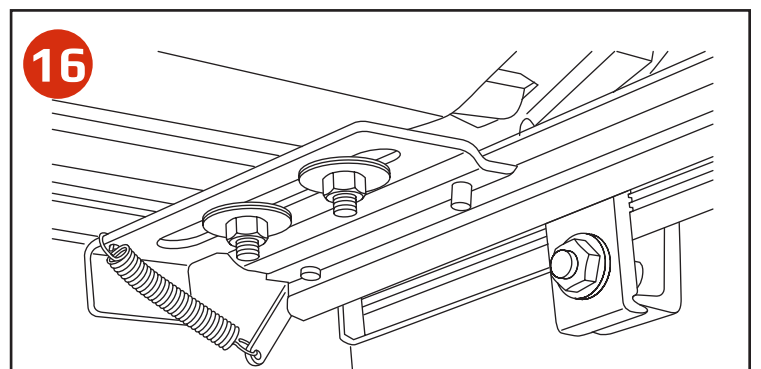

16

Once properly aligned, roll the cover open ensuring you DO NOT misalign the roll top. Tighten the nylon lock nuts at the front to secure the cover, DO NOT overtighten the fasteners. Hand tighten; DO NOT use power tools or impact drivers. Recheck that the roll top operates correctly. When latched check that the locking rails prevent the cover from lifting on both sides.

17

Check to see that the latches at the tailgate fully engage and make proper contact with side rails.

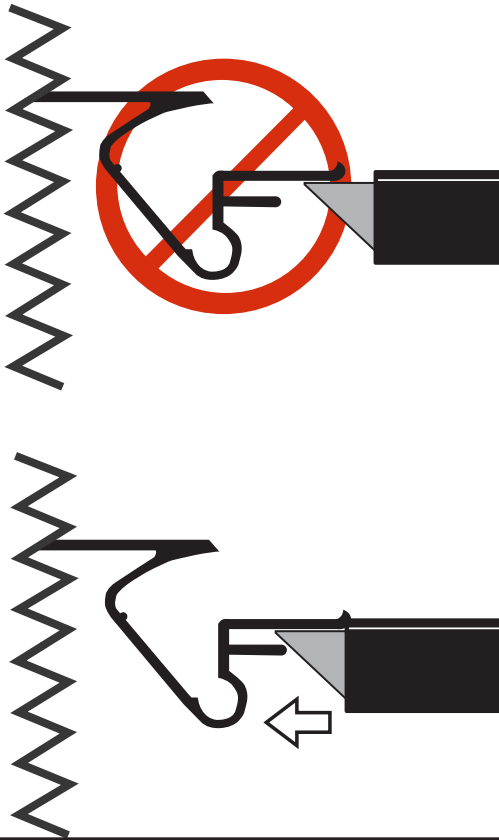

18

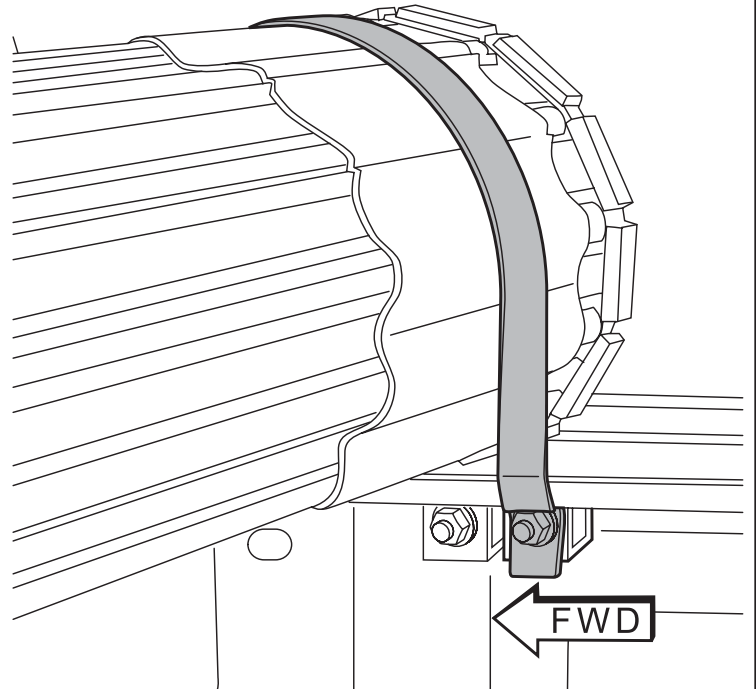

Mount the strap clamp assembly as far forward on the rail as possible and tighten. Repeat on the opposite side.

19

! IMPORTANT

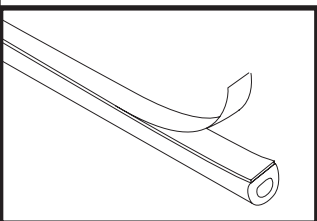
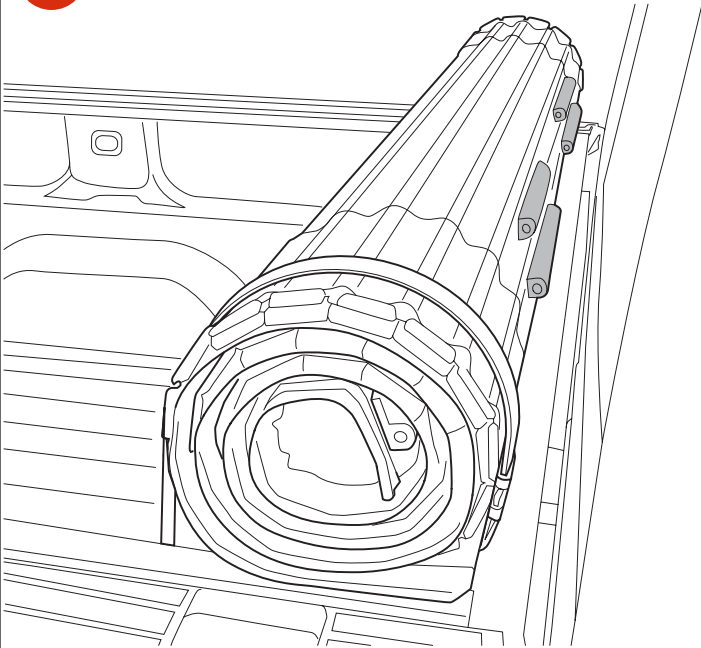

Roll the cover open and place the D shaped bumpers to the aluminum underside where they will prevent contact if the cover is rolled all the way open. The straps will hold the cover off the cab and glass when secured.

20

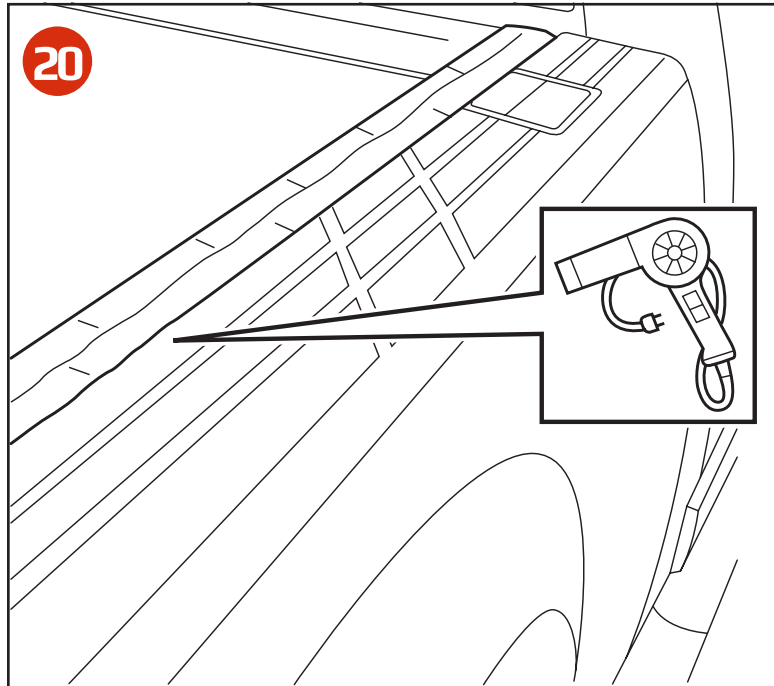

If the side seals of the cover appear wrinkled you may leave the truck in the sun to assist the seals to lay flat. To expedite, apply heat with a hair dryer or heat gun.

IMPORTANT Safe operation and use

IMPORTANT NOTICE

While driving, cover must be completely flat and secure with BOTH rear latches engaged and in the closed position OR completely rolled up and secured at the cab with the provided straps. **DO NOT DRIVE** with cover partially opened.

Tonneau Cover Positions While Operating Vehicle

Prior to vehicle operation, tonneau cover MUST be properly secured.

CLOSED POSITION (FIG 1)

Cover must be closed and **FULLY LATCHED ON BOTH SIDES** of the tonneau side rails.

OPEN POSITION (FIG 2)

To drive with your cover in the open position, simply make use of the provided tie down straps. Roll the cover forward and stop approximately 4" from the cab and insert the strap clips into the buckles at the end of the cover. Ensure BOTH strap clips are fully inserted and tighten the straps with the adjustment locks to ensure the cover doesn't roll or shift during vehicle operation.

Cover Operation

TO CLOSE THE COVER (FIG 3)

Roll the top towards the tailgate and rotate the tail rail downwards towards the rotating locking levers.

WARNING – When closing the cover ensure rear latches on BOTH sides are fully engaged underneath the rails before operating the vehicle.

TO OPEN THE COVER (FIG 4)

Pull downwards on latch release cable located on either side of the cover and rotate tail rail forward and into a rolling motion. Cover should be rolled into a bundle towards the cab of the vehicle and only driven with the cover secured with the provided straps.

DO NOT ATTEMPT TO DRIVE WITH THE COVER IN THE PARTIALLY OPEN POSITION!

ADDITIONAL IMPORTANT OPERATING TIPS

- Tonneau cover MUST be free of foreign material including snow and ice before opening rail top.
- Do NOT tow your vehicle from the rear with the tonneau on your truck.
- Do NOT operate vehicle with objects on top of cover.

FAILURE TO FOLLOW THESE CAUTIONS MAY RESULT IN SEVERE DAMAGE AND WILL VOID YOUR WARRANTY!



matter before rolling cover.



Do NOT tow your vehicle from the rear with this cover on your truck.

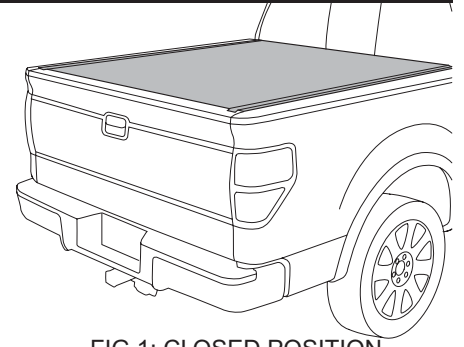

FIG 1: CLOSED POSITION

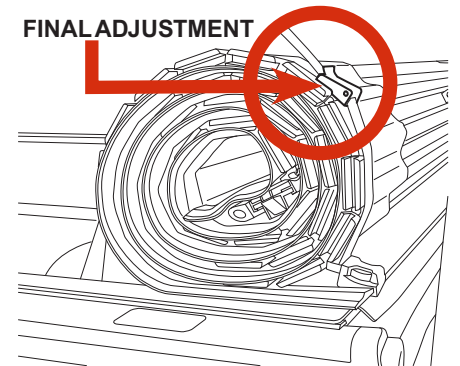

FIG 2: OPEN POSITION

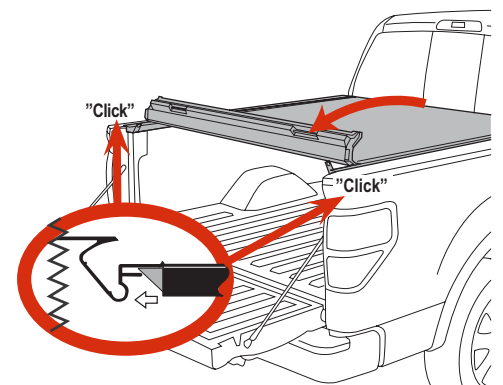

FIG 3: TO CLOSE THE COVER

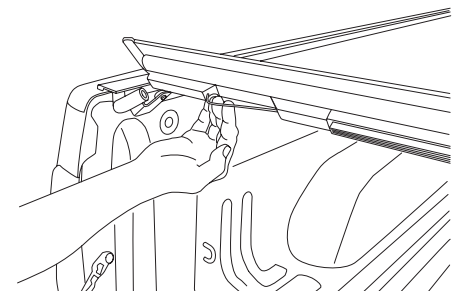

FIG 4: TO OPEN THE COVER

Warranty

BAK® Industries ("BAK") warrants your BAKFlip Hard Folding Cover to be structurally free from defects in material and workmanship for the period as outlined in the table below from the retail date of purchase. Warranty registration must be on file and/or proof of original purchase (detailed and dated receipt) required for warranty service. Warranty is non-transferable and applies to the original purchaser of the BAK product only.

PRODUCT	WARRANTY PERIOD	REGISTER YOUR WARRANTY NOW AT BAKINDUSTRIES.COM
Revolver X2	3 Year Limited Warranty	
Revolver X4	5 Year Limited Warranty	

BAK reserves the right to determine whether a product needs to be repaired or replaced. No labor or service allowance is given or implied. The warranty will be void if the product has been damaged by accident, unreasonable use, neglect, improper service/installation/removal, modifications, acts of God or normal wear and tear or other causes not arising out of defective materials or workmanship. BAK assumes no liability for injury, loss, incidental or consequential damages. BAK reserves the right to substitute an entire replacement system or provide other remedies than those listed in this warranty for discontinued products or other reasons. Shipping charges will apply for any repair or replacement.

Improper cleaning may also void your warranty. It is recommended to use the approved BAK treatment of the vinyl as outlined below or clean with soap and water only. Do not use vinyl conditioners (i.e. Armor All®) because they will shrink the vinyl.

BAK is committed to providing you with our best service at all times. Please feel free to contact us should you require any assistance with your BAK product.

CARE AND MAINTENANCE

The tonneau covers are made from durable materials and require simple care to ensure a long life of performing well and looking great.

Cleaning the Top (Washing)

These stylish covers incorporate OE marine grade vinyl laminated on the top surfaces. Standard automotive soap and water used with a soft sponge or cloth is recommended for cleaning. Shammy dry to prevent water spots and ensure a rich dark finish.

Treating the Vinyl Top

3M™ 303® Aerospace Protectant may be used to keep the vinyl surface clean and protected from the elements and will also remove any water spots that may have developed. 303 Aerospace not only protects against fading, discoloration and cracking from harmful UV rays, but repels dust and stains. Simply spray on and wipe dry for a beautiful, matte finish that protects your cover from road grime and dust. Do not use vinyl conditioners (i.e. Armor All®) because they will shrink the vinyl.

Maintenance

It is recommended that you periodically check that the cover is securely attached to your truck bed. Inspect the clamps and front mounting bolts to ensure they were properly installed and have not come loose or knocked out of adjustment during operation. Covers that are used with high frequency or that are subject to the vibrations and impact from rough roadways can cause the cover to require adjustment.

Lubricating the Latches

It is recommended that you periodically inspect and service the latches on the end of the roll top. Clean away any excess dirt or grime and use a spray lubricate. Ensure the latches move freely in and out to properly engage the side rail and provide proper performance with optimum security. Be careful not to overspray the cover. Wipe away any excess around the latch location.

Learn more about tonneau covers on our website <http://4x4ok.com>